

MPL Installation Notes

(Standard MPL - PVCu / composite door applications)

Please read before installation!

Door and frame must be of an approved pattern and be **ROUTED** in accordance with respective MPL drawings.

Screws used should have countersunk heads, be of a suitable length and be one or more of the following type/s: -

- Drill point M4 / 3.9mm self-tapping for metal reinforced PVCu profiles.
- Type AB (No.8) 4.2mm (or 4.8mm 'repair' screws) self-tapping or equiv. 'HiLo' for un-reinforced PVCu.
- Wood pattern (No.8) or equivalent self-tapping for wood / wood fibre / composite.

Please note: high security applications (i.e. Pas 24) using PVCu must use profile with Steel or Aluminium reinforcement of an adequate thickness. Reinforcement must be accessible for screws adjacent all locking points and for at least one screw at each end of each keep.

Keeps: fit the appropriate profile packers to the keeps for PVCu systems. Orient packers to engage with keep retaining strip. Push firmly the plastic tabs to clip into the keeps elongated holes.
See opposite →

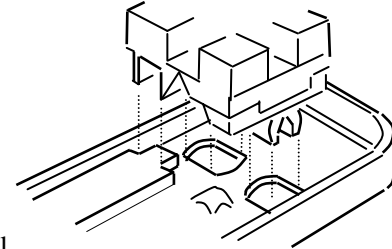

Keeps should be positioned on the frame to provide equal \pm door vertical tolerance to the lock points with the door centralised in the frame, i.e. as follows: -

- Deadbolt (PVCu only) should be approximately 6mm below the top of the keep deadbolt aperture – **Fig 1.**
- Individual rollers / mushrooms should enter their keep 'mouth' centrally when closing the door – **Fig 2.**
- Hooks should be well engaged into their keep, nominal clearance 3mm from hook throat to keep aperture (measured vertically when locked) - **Fig 3.**
- Combined Hook / Roller keeps, set for the roller as above.
- Linear bolts should have an equal gap above and below between the bolt and the keep aperture.

Please note: High security applications (i.e. Pas 24) - clearance between the door edge and the keeps should be minimised. Door riser blocks are recommended in such applications behind hinges and on the top & bottom rails above & below lock sash edge.

Please note: Keep pre-installation centre slot, if provided, will allow some vertical adjustment prior final fastening. Firstly fit the keep with this screw alone for such adjustment purposes. See **Fig 1.** below.

Keep Adjustment: Keeps may be adjusted to give the profile / system manufacturers recommended seal compression. Firstly loosen keep retaining screws and slide the keep or keep insert on its slotted screw holes, if provided, then re-tighten using a hand-screwdriver. Eccentric rollers may be rotated \pm 1/4 of a turn – See **Fig 4.** (basic composite door keeps can only be adjusted prior to fitting the last screws into the non-slotted holes).

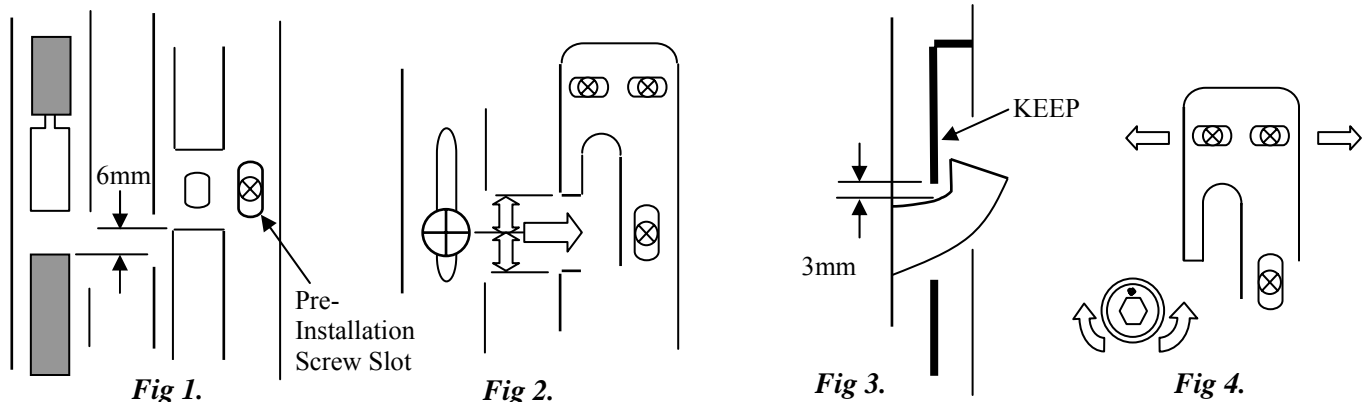

MPL Installation Notes

(Standard MPL - PVCu / composite door applications)

Please read **before** installation!

Trimming of bar ends (non-shootbolt applications) - trim bars in the locked mode (deadbolt thrown). Bars may be trimmed anywhere outboard of either end locking point to suit door sash length. **Please note:** Check firstly all associated keeps will be at an acceptable position on the frame.

Fitting Shootbolts: for MPL's with a 16mm wide face bar of a type that facilitates shootbolts for the desired door length. **NB Small doors** - a different handle height or use of a different MPL type may facilitate fitment – ask your MPL supplier! Firstly fit the shootbolts to the door then offer the MPL in position in the unlocked mode (deadbolt withdrawn). Mark the MPL face bar 3mm (1 - 9) short of the shootbolt outer bar (155mm [153-161] short of the end of the sash) - See **Fig 5**. **Please note:** Check for acceptable engagement of the toothed 'drive-bar' into the shoot-bolt receiver block - See **Fig 6**. **Do not proceed if measurements are less!** Remove MPL from the door and cut its bars to length (de-burr after cutting!). Fasten the MPL to the door with the toothed 'drivebars' engaged with the shootbolt receiver blocks. Finally tap the shootbolt flags over to cover the sawn bar ends, fit the screws in the now exposed holes – See **Fig 7**. NB Plastic location pegs shear-off when the lock is first operated.

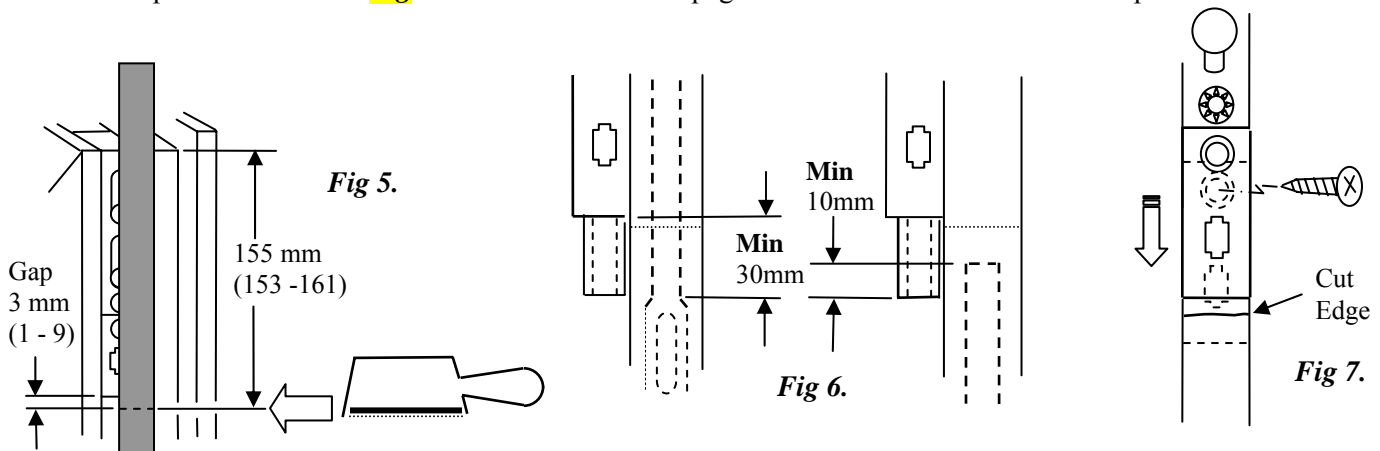

Reversing the latchbolt - Before installing the MPL, remove the 2 screws in the latch-bolt. Pull out the latch-bolt, rotate it ½ turn then immediately replace it back in the lock. Refit the screws and re-tighten firmly -See **Fig 8**.

Reversing the 'nightlatch' functionality (for use with a split-spindle: the inside handle **only** should operate the latch-bolt, from outside the latch-bolt is key operated). Before installing the MPL, using a handle & spindle, throw the deadbolt fully. Remove the latch-bolt as described above. With a small flat screwdriver, gently rotate the peg in the aperture where the latch-bolt came ½ turn (clockwise). Refit the latch-bolt as described above - See **Fig 9**.

TROUBLE SHOOTING -If, particularly after reversing, the latch-bolt will not retract using either handle (or pad) - **do not force!** Repeat the above procedure, **except** this time rotate the peg only ¼ of a turn anti-clockwise (slot in line with the lock!) and then throw the deadbolt fully. Now rotate the peg back ¼ of a turn clockwise. Re-fit the Latch-bolt and retry - See **Fig 10**.

