

CHALLENGER 3D BUTT HINGES ADJUSTMENT INSTRUCTIONS

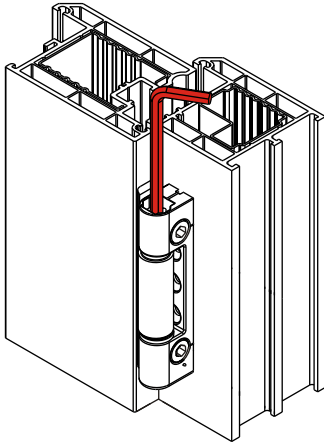

COMPRESSION ADJUSTMENT +0.5mm -0.5mm (5mm Allen Key)

REMOVE THE TOP CAP.

CHECK PIN ALIGNMENT VIA MARK ON TOP OF PIN. IF THE MARK IS POINTING TOWARDS THE DOOR SASH, THE ADJUSTMENT IS IN THE NEUTRAL SETTING.

TO INCREASE COMPRESSION, TURN THE PIN SO THAT THE ALIGNMENT MARK IS MOVED TOWARDS THE DOOR FRAME.

TO REDUCE COMPRESSION, TURN THE PIN SO THAT THE ALIGNMENT MARK MOVES AWAY FROM THE FRAME.

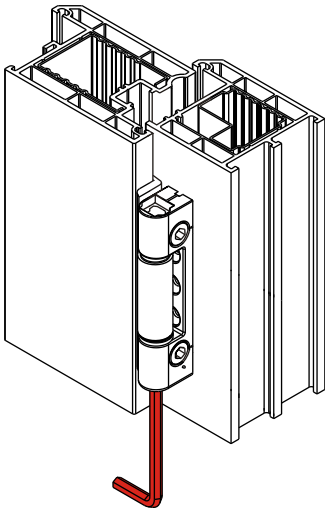

VERTICAL ADJUSTMENT +3.0mm - 0.0mm (5mm Allen Key)

REMOVE THE BOTTOM CAP.

TO RAISE DOOR SASH, ROTATE THE VERTICAL ADJUSTMENT SCREW CLOCKWISE. ENSURE THAT ALL OTHER HINGES ARE ADJUSTED EQUALLY.

TO LOWER DOOR SASH ROTATE THE VERTICAL ADJUSTMENT SCREW ANTI CLOCKWISE. ENSURE THAT ALL OTHER HINGES ARE ADJUSTED EQUALLY.

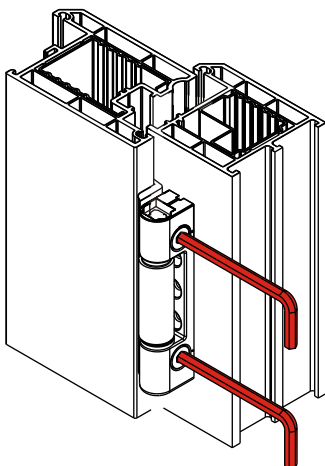

LATERAL ADJUSTMENT +2.0mm -2.0mm (4mm Allen Key)

REMOVE THE SIDE COVER CAPS.

ROTATE THE LATERAL ADJUSTMENT DRIVES IN THE DIRECTION REQUIRED. ENSURE THAT EACH PAIR OF ALIGNMENT MARKS ARE AT THE SAME POINT.

WARNING

IT IS NOT RECOMMENDED TO FULLY ADJUST EITHER ONE ADJUSTER ONLY OR ONE HINGE ONLY. ADJUSTMENTS SHOULD BE MADE GRADUALLY, ALIGNING EACH PAIR OF MARKS ON EACH HINGE UNTIL THE DESIRED ADJUSTMENT IS ACHIEVED.

Part No.	Description
DAMSOT0001	4mm Allen Key
DAMSOT0002	5mm Allen Key